

INSTALLATION GUIDE

Union Reducer

Model Type Code: UNRD

Visit www.smartlockfitting.com for video guide

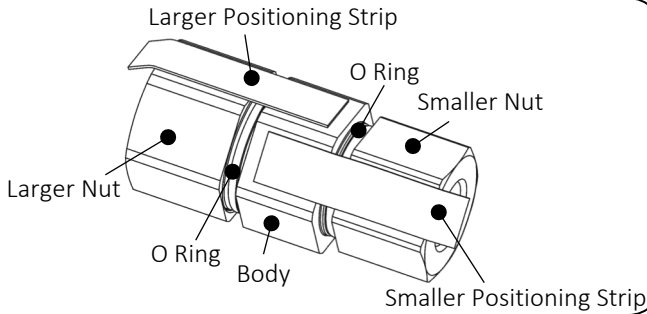

1 Start with the larger side. Insert the Larger Tube into Larger Nut until Tube stops.

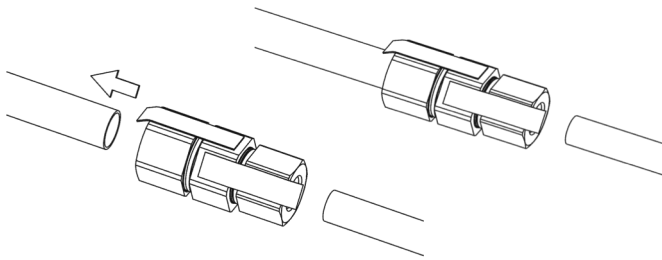

2 Remove the Larger Positioning Strip from the Larger Nut and Body.

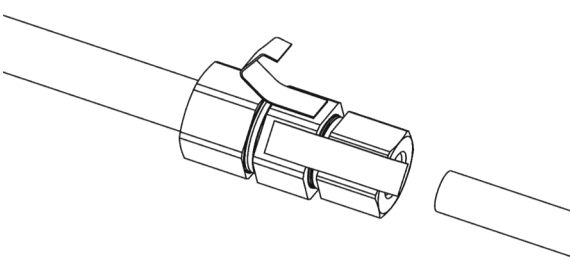

3 Hold Body and then hand tighten Larger Nut until Tube locks.

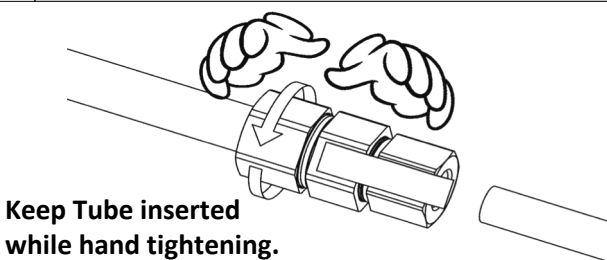

4 Insert Smaller Tube into Smaller Nut. Push until Tube stops.

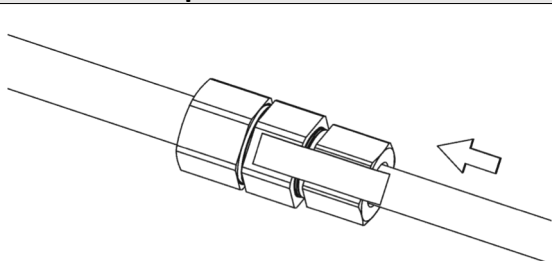

5 Remove Smaller Positioning Strip from the Smaller Nut and Body.

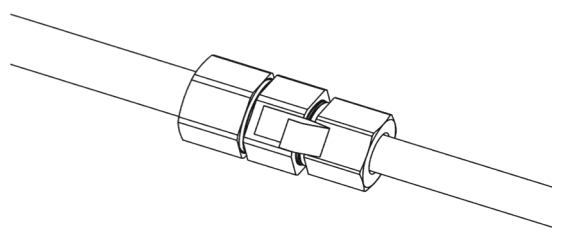

6 Hold Body and then hand tighten Smaller Nut until Tube locks.

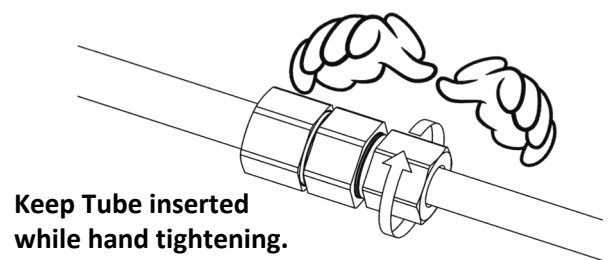

7 Fasten with wrenches. While holding the Body, tighten the Larger Nut FIRST and then the Smaller Nut.

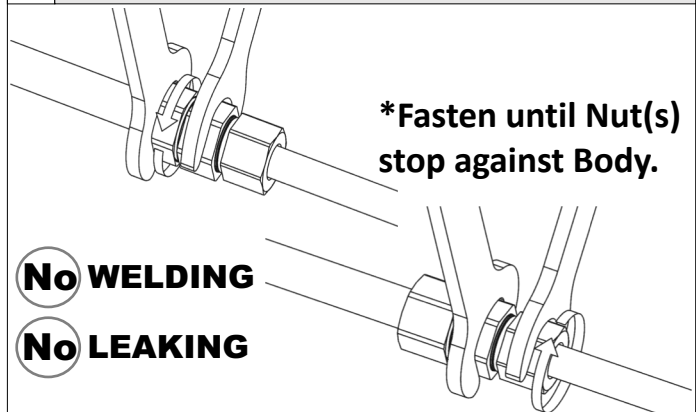

No WELDING

No LEAKING

*Torque values available on website if desired

CAUTION

1. DO NOT REUSE.
2. DO NOT REMOVE POSITIONING STRIP PRIOR TO ASSEMBLY.
3. REMOVE BURRS FROM TUBING WITH CHAMFERING OR DEBURRING TOOL.
4. DO NOT USE DAMAGED TUBE AT 2 INCH FROM THE END OF THE TUBE.
5. DO NOT BEND TUBE AFTER CONNECTION IS MADE.
6. DO NOT USE OTHER THAN FOR INTENDED PURPOSE.



HVAC/R

Fitting & Valve

800 Port American Place #100 Grapevine, TX 76502

TEL: 980-333-4530 / FAX: 908-231-2094

sales@smartlockfitting.com

www.smartlockfitting.com